

# Appendix: Analog Switch Array Measurements

---

MT8806/08/09/12/14/15/16 ANALOG SWITCH ARRAY FAMILY:

## TEST CIRCUITS FOR KEY PARAMETER MEASUREMENTS

- A.1 Off-State Leakage Current ( $I_{OFF}$ ) Measurement
- A.2  $R_{ON}/\Delta R_{ON}$  vs.  $V_{DC}$  Measurements
- A.3 Frequency Response ( $F_{3dB}$ ) Measurement
- A.4 Feedthrough (FDT) Measurement
- A.5 Crosstalk ( $X_{talk}$ ) Measurement
- A.6 Control Input Crosstalk ( $CX_{talk}$ ) Measurement
- A.7 Control Memory Timing Measurements

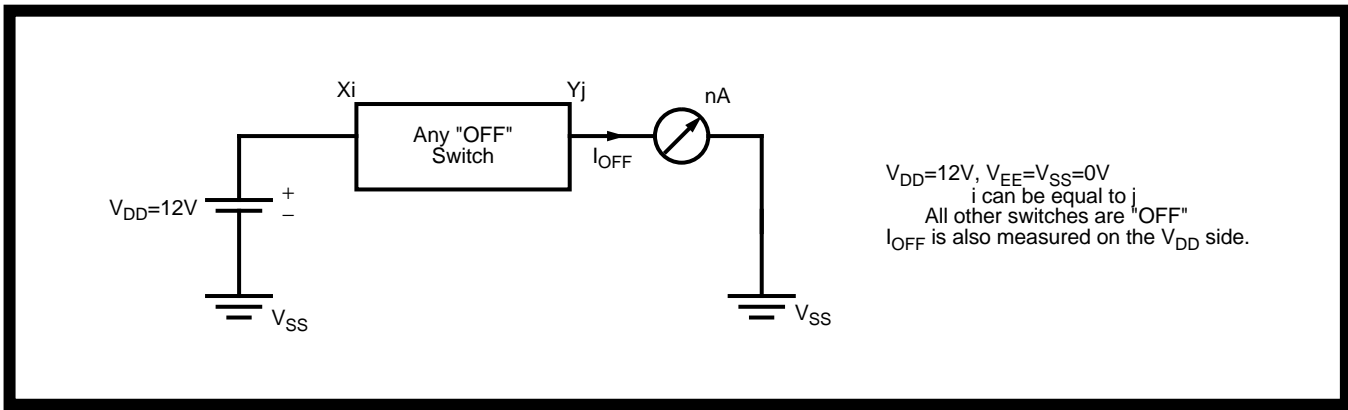

Figure A.1 - Off-State Leakage Current ( $I_{OFF}$ ) Measurement\*

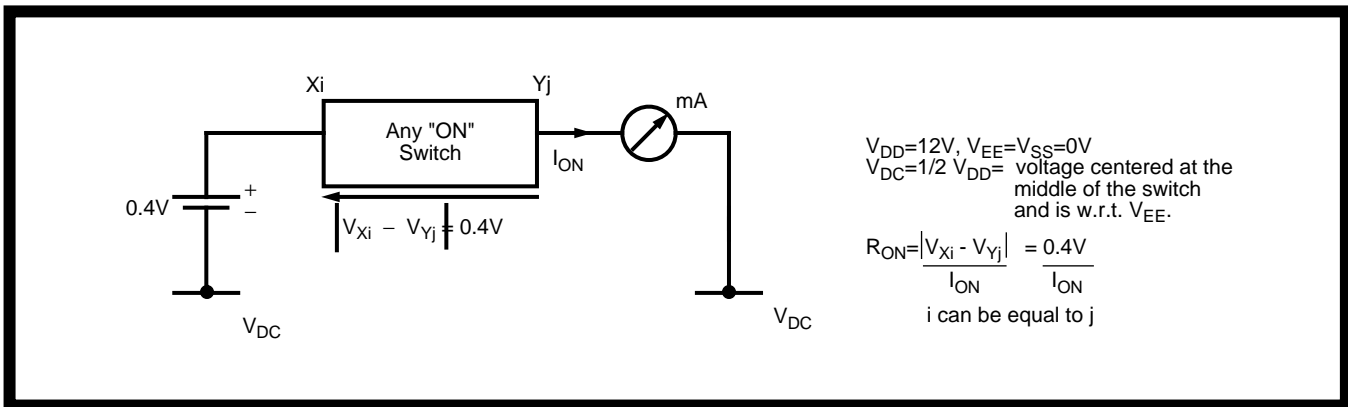

Figure A.2 -  $R_{ON}/\Delta R_{ON}$  Measurement \*

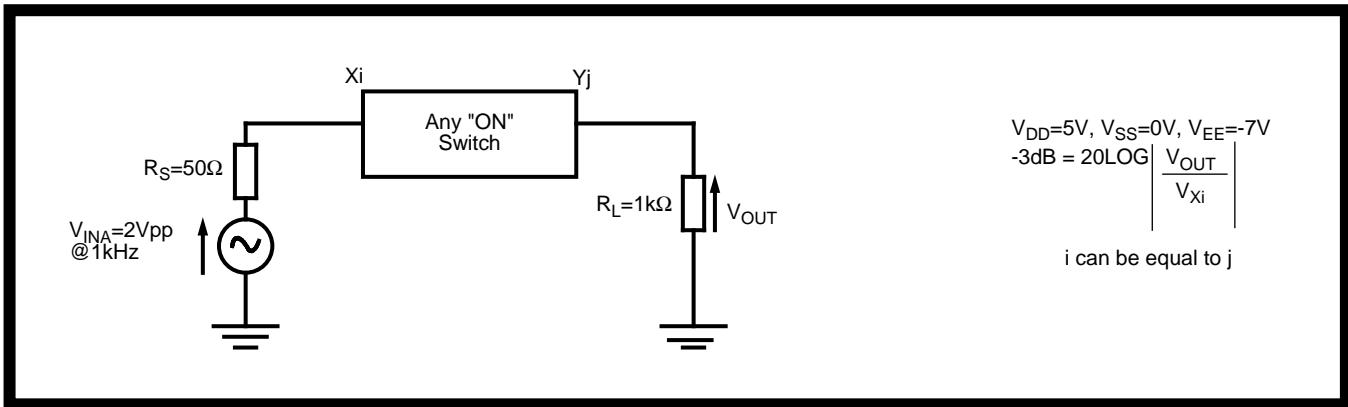

Figure A.3 - Frequency Response ( $F_{3dB}$ ) Measurement †

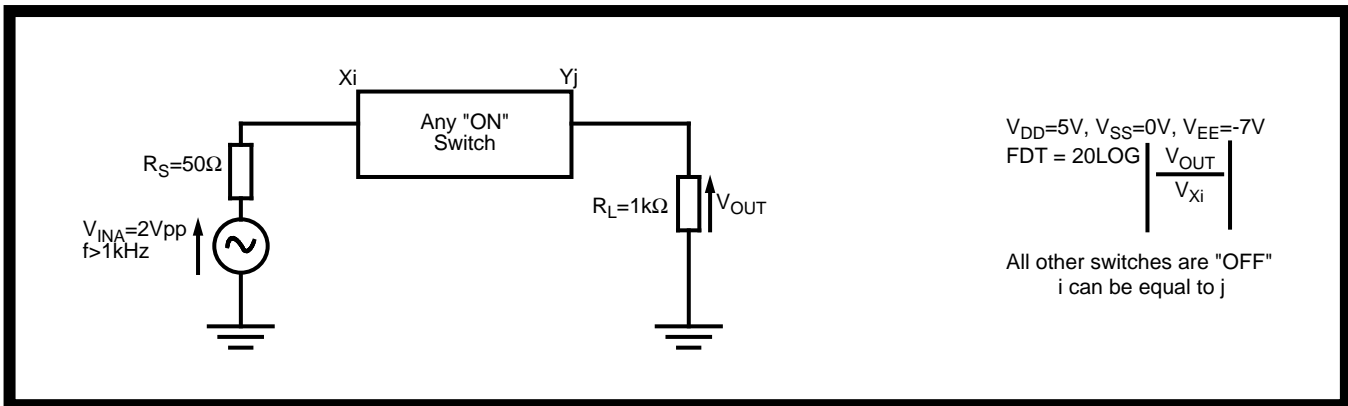

Figure A.4 - Feedthrough (FDT) Measurement †

Notes:

\* Test Conditions for MT8809 and MT8812 are respectively:  $V_{DD}=12V, V_{SS}=0V$  and  $V_{DD}=14V, V_{SS}=0V$ .

† Test Conditions for MT8809 and MT8812 are respectively:  $V_{DD}=5V, V_{DC}=0V, V_{SS}=-7V$  and  $V_{DD}=7V, V_{DC}=0V, V_{SS}=-7V$ .

All  $X_i$  and  $Y_j$  analog I/O pins can be interchanged for all measurements.

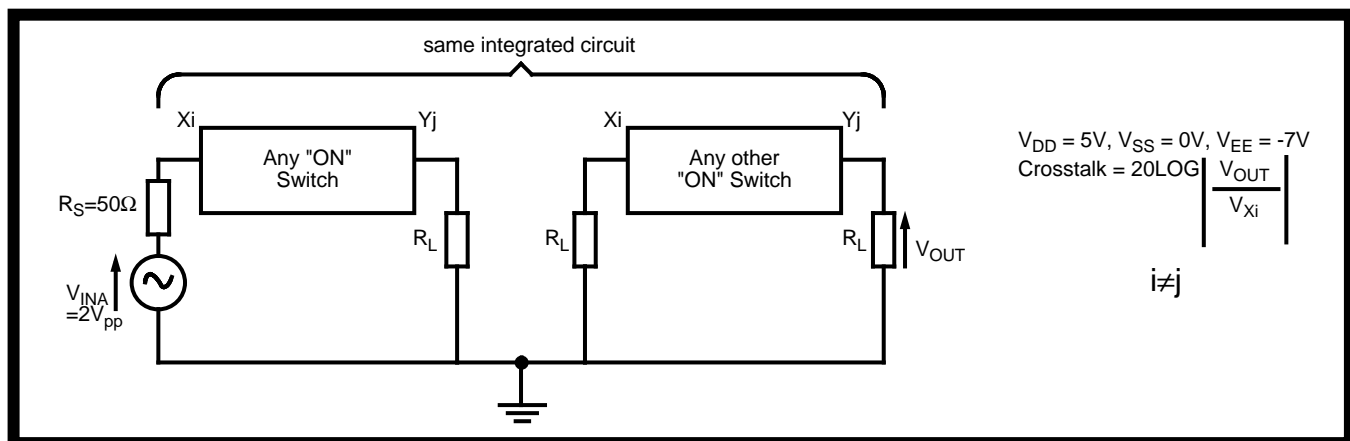

Figure A.5 - Crosstalk ( $X_{talk}$ ) Measurement †

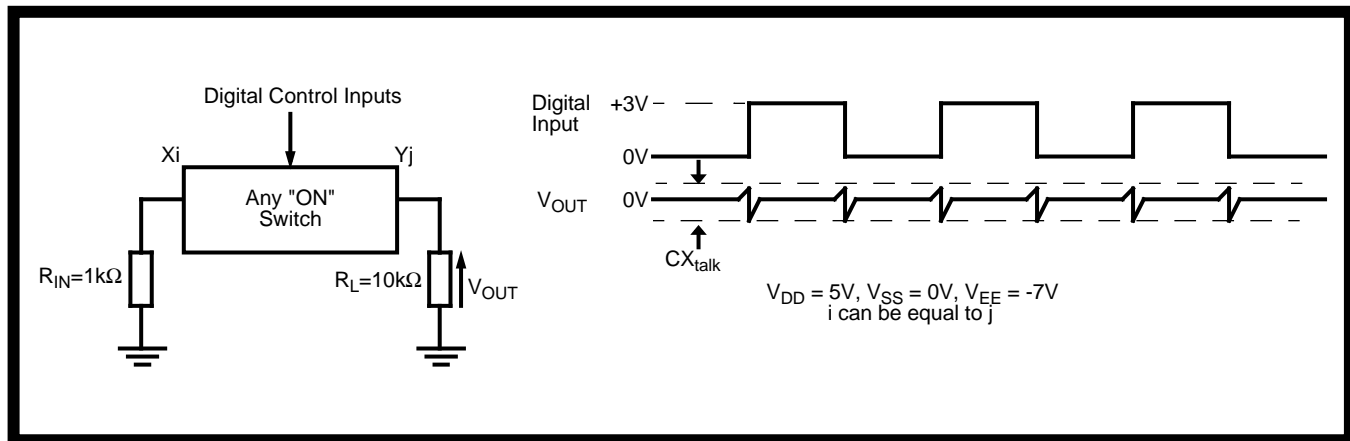

Figure A.6 - Control Input Crosstalk to Switch ( $CX_{talk}$ ) †

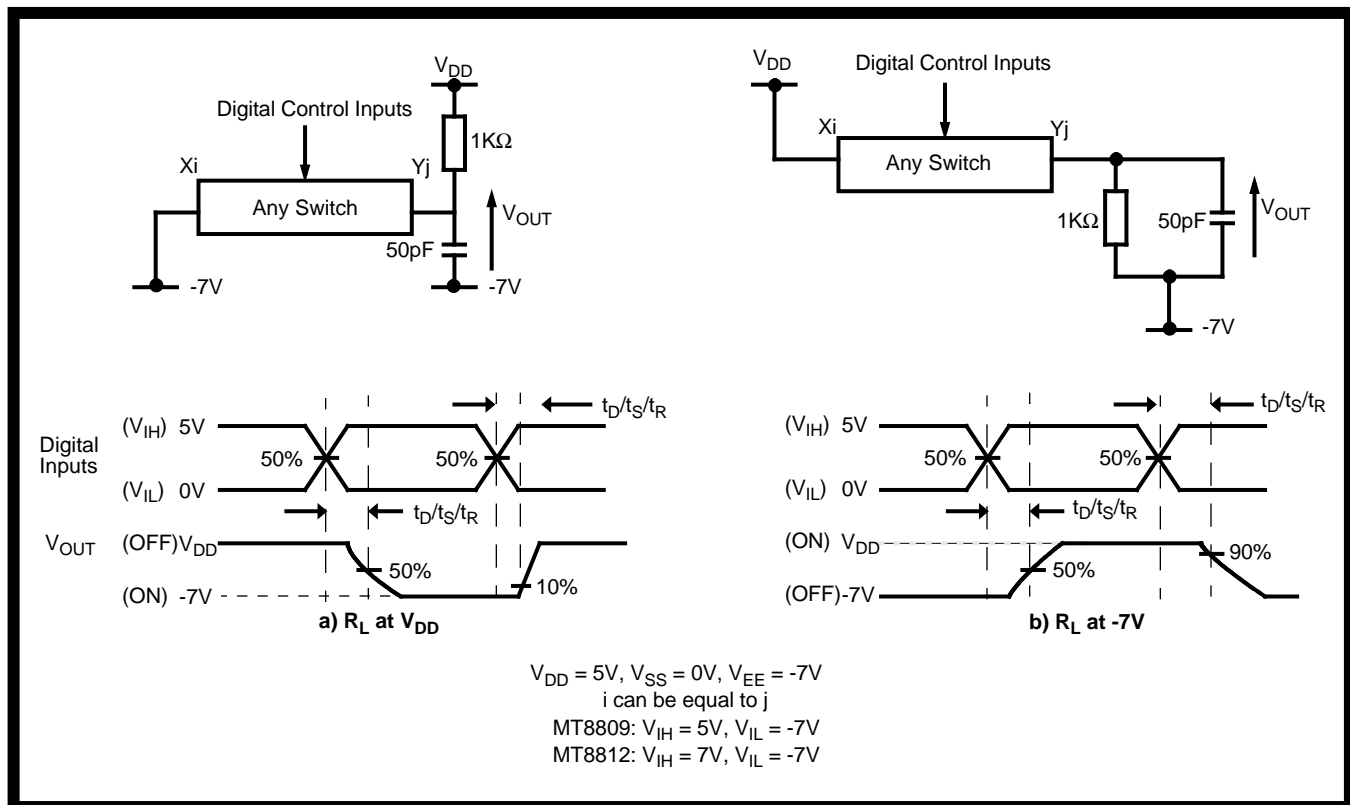

Figure A.7 - Control Memory Timing Measurements †

Notes:

† Test Conditions for MT8809 and MT8812 are respectively:  $V_{DD}=5V, V_{DC}=0V, V_{SS}=-7V$  and  $V_{DD}=7V, V_{DC}=0V, V_{SS}=-7V$ . All  $X_i$  and  $Y_j$  analog I/O pins can be interchanged for all measurements.

### MT8806/08/09/12/14/15/16 ANALOG SWITCH ARRAY FAMILY:

#### TYPICAL GRAPHS FOR SELECTED PARAMETERS

- G.1 On-state Resistance ( $R_{ON}$ ) vs. Temperature @  $V_{DD}=5V, 10V, 12V$
- G.2 On-state Resistance ( $R_{ON}$ ) vs. DC Offset ( $V_{DC}$ ) @  $V_{DD}=5V, 10V, 12V$  @  $25^{\circ}C$
- G.3 On-state Resistance ( $R_{ON}$ ) vs. DC Offset ( $V_{DC}$ ) @  $V_{DD}=12V$  @  $-40^{\circ}C, 25^{\circ}C, 85^{\circ}C$
- G.4  $\Delta R_{ON}$  vs. Temperature @  $V_{DD}=5V, 10V, 12V$
- G.5 Total Harmonic Distortion (THD) vs. Frequency
- G.6 Total Harmonic Distortion (THD) vs. I/P Signal Amplitude ( $V_{peak}$ )
- G.7 Crosstalk ( $X_{talk}$ ) vs. Frequency
- G.8 Feedthrough (FDT) vs. Frequency
- G.9 Off-State Leakage Current ( $I_{OFF}$ ) vs. Switch Voltage

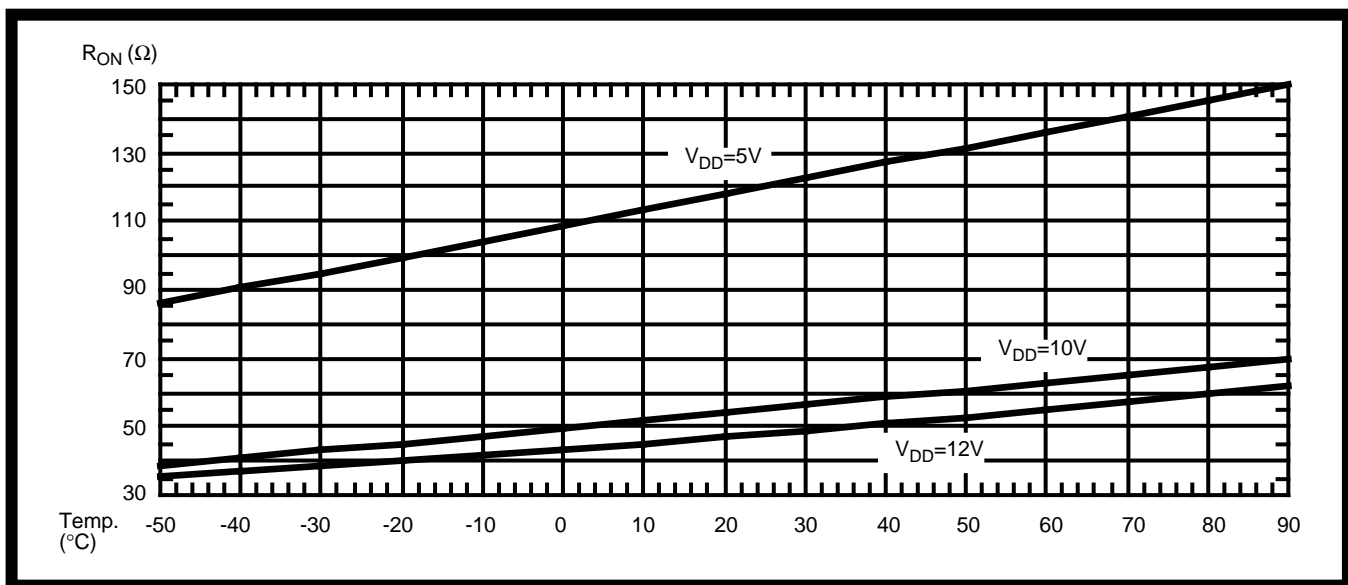

G.1 - On-State Resistance ( $R_{ON}$ ) vs. Temperature

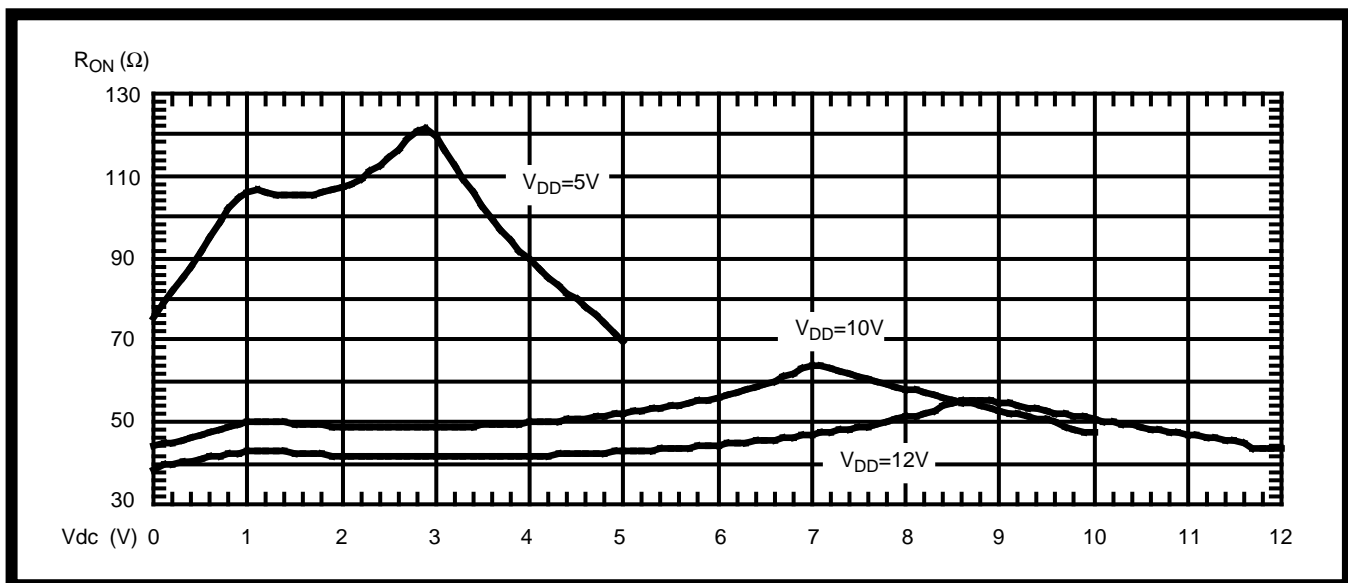

G.2 - On-State Resistance ( $R_{ON}$ ) vs. DC Offset ( $V_{DC}$ ) @ 25°C

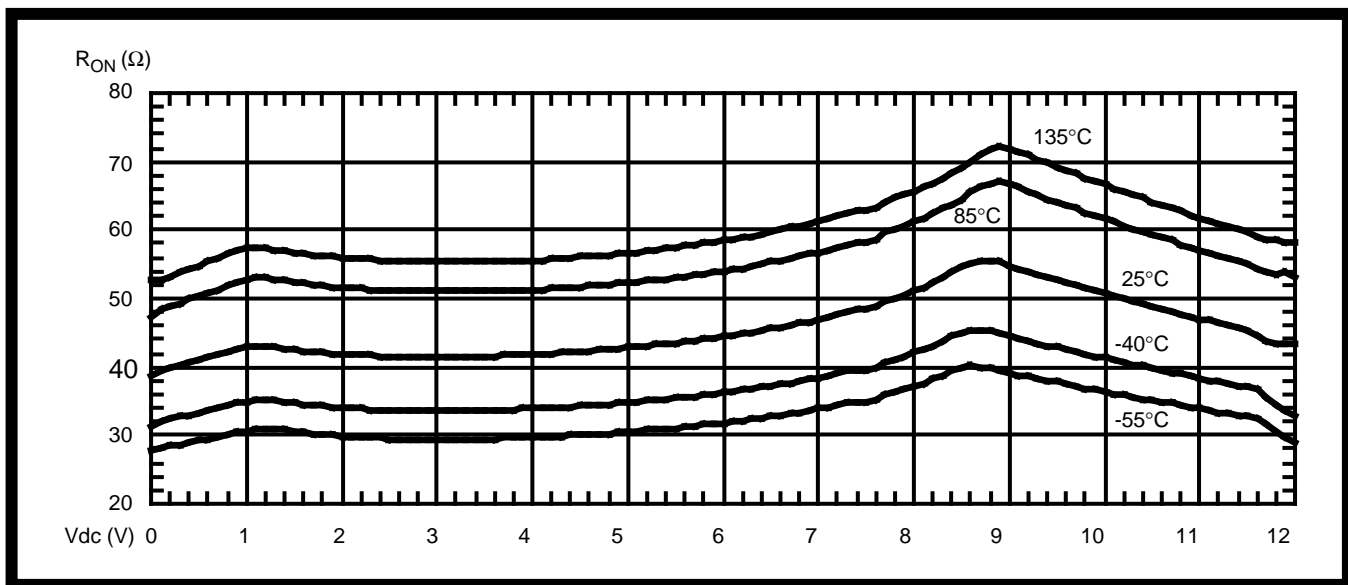

G.3 - On-State Resistance ( $R_{ON}$ ) vs. DC Offset ( $V_{DC}$ ) @  $V_{DD} = 12V$

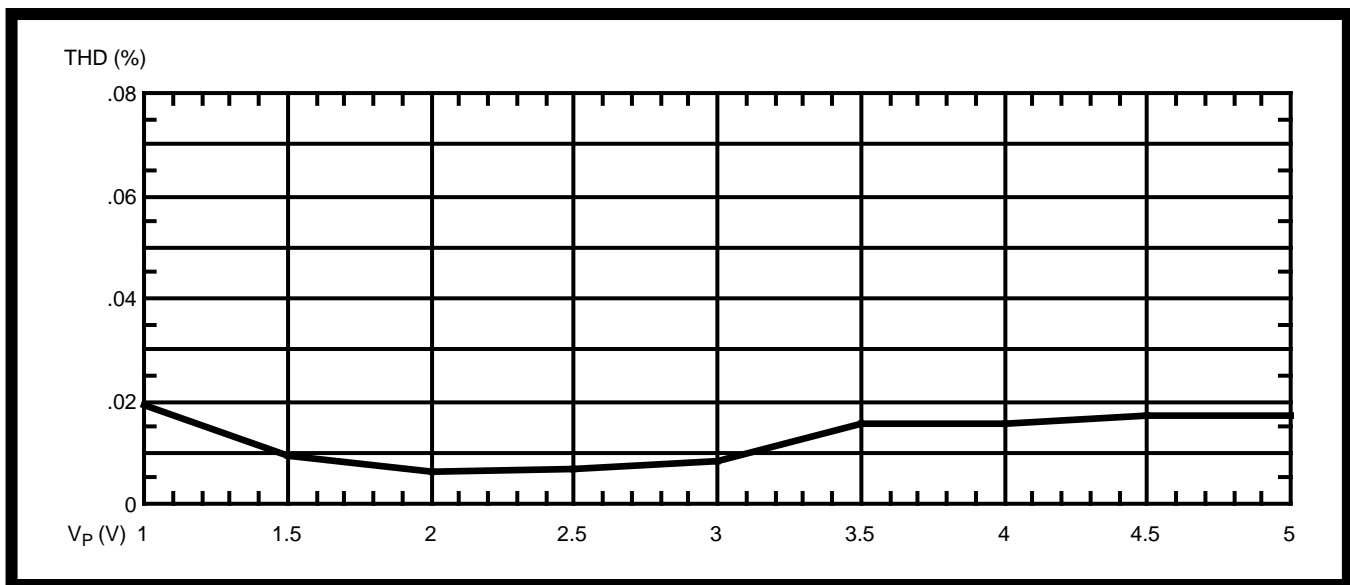
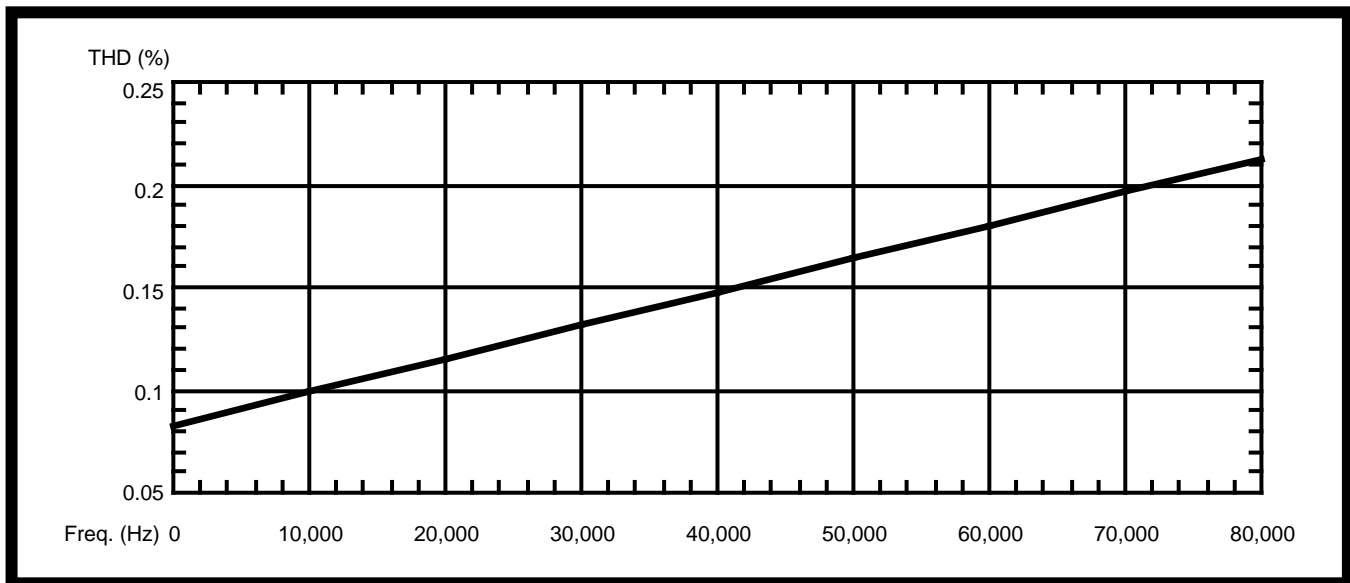
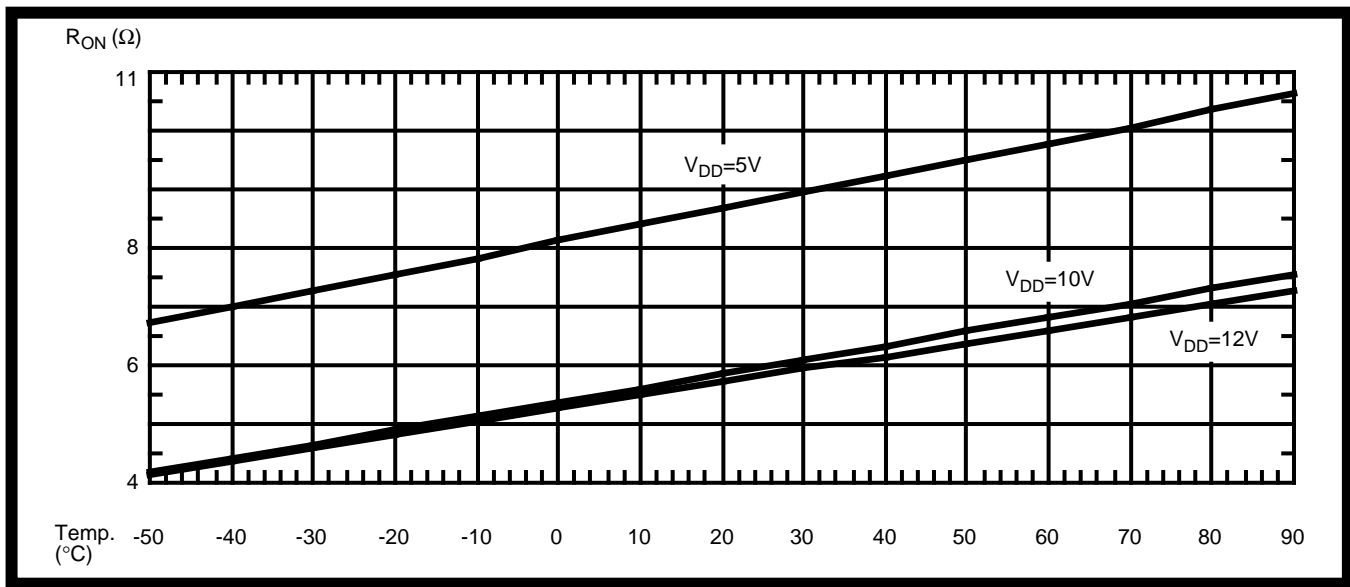

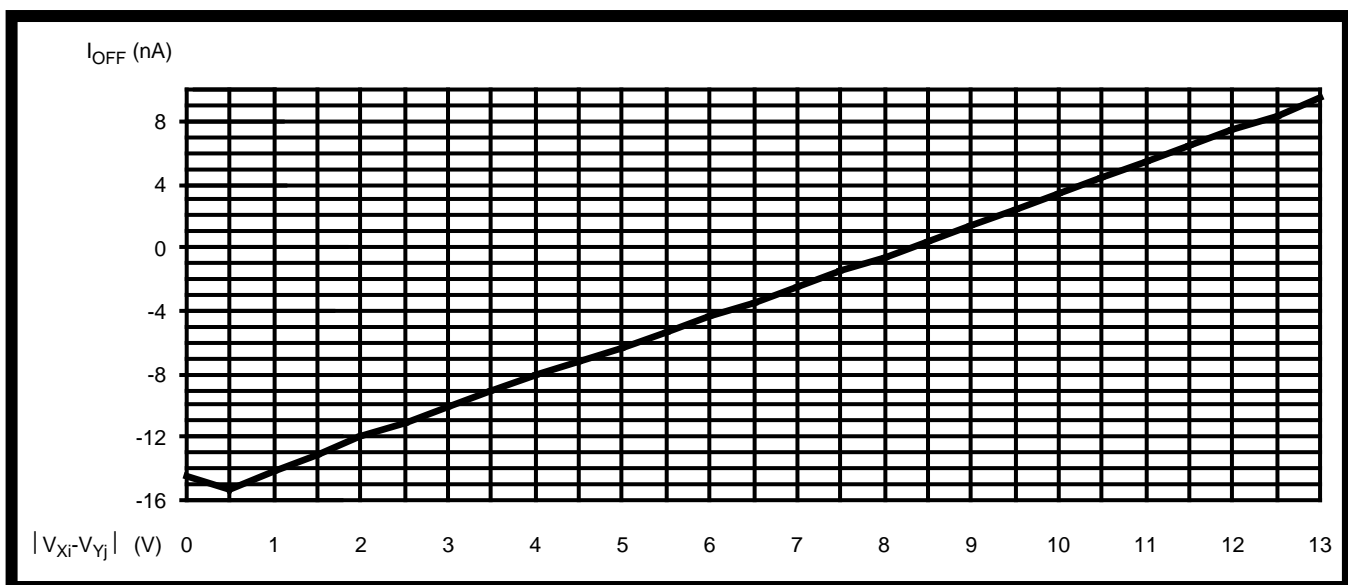
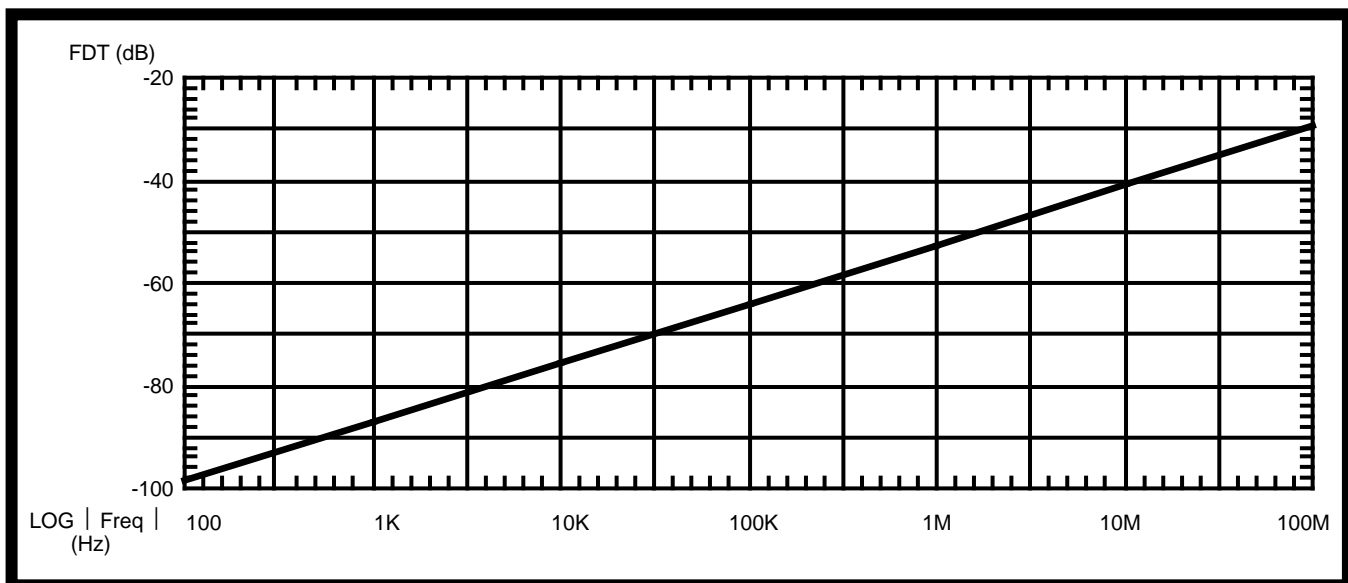
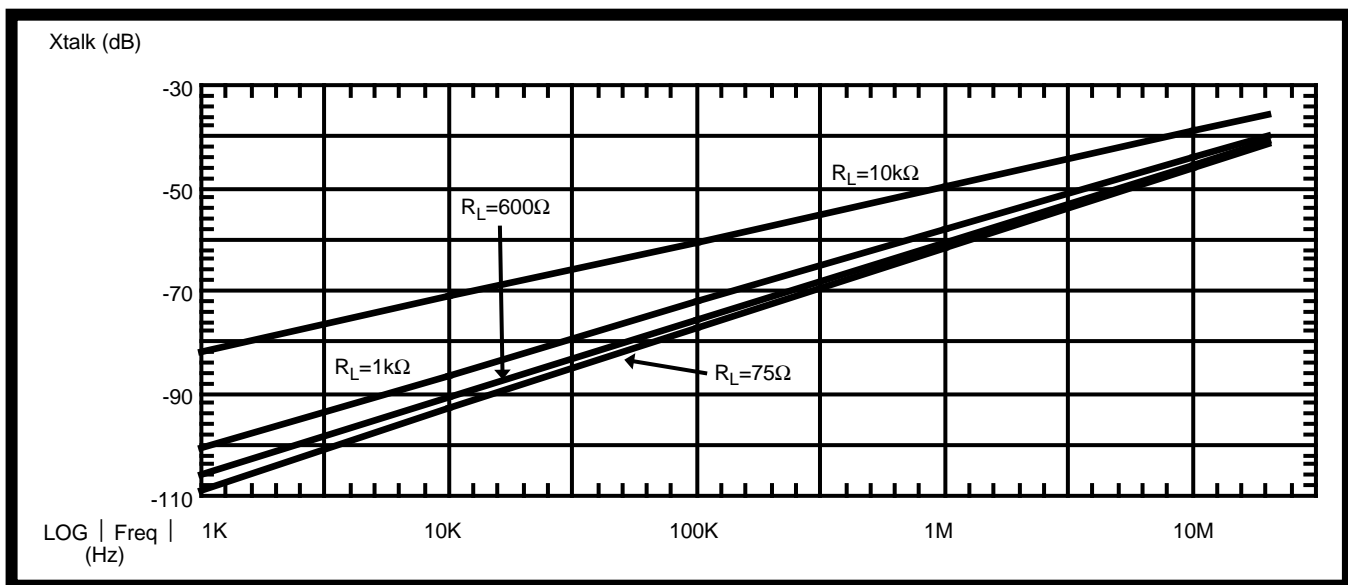

MT8806/08/09/12/14/15/16 ANALOG SWITCH ARRAY FAMILY:

Analog Switch Array Applications

The analog switch array is shown in Figure A.8 as a switching matrix for a typical key system. The system shown below allows connection of outside Central Office telephone lines to inside extension telephones.

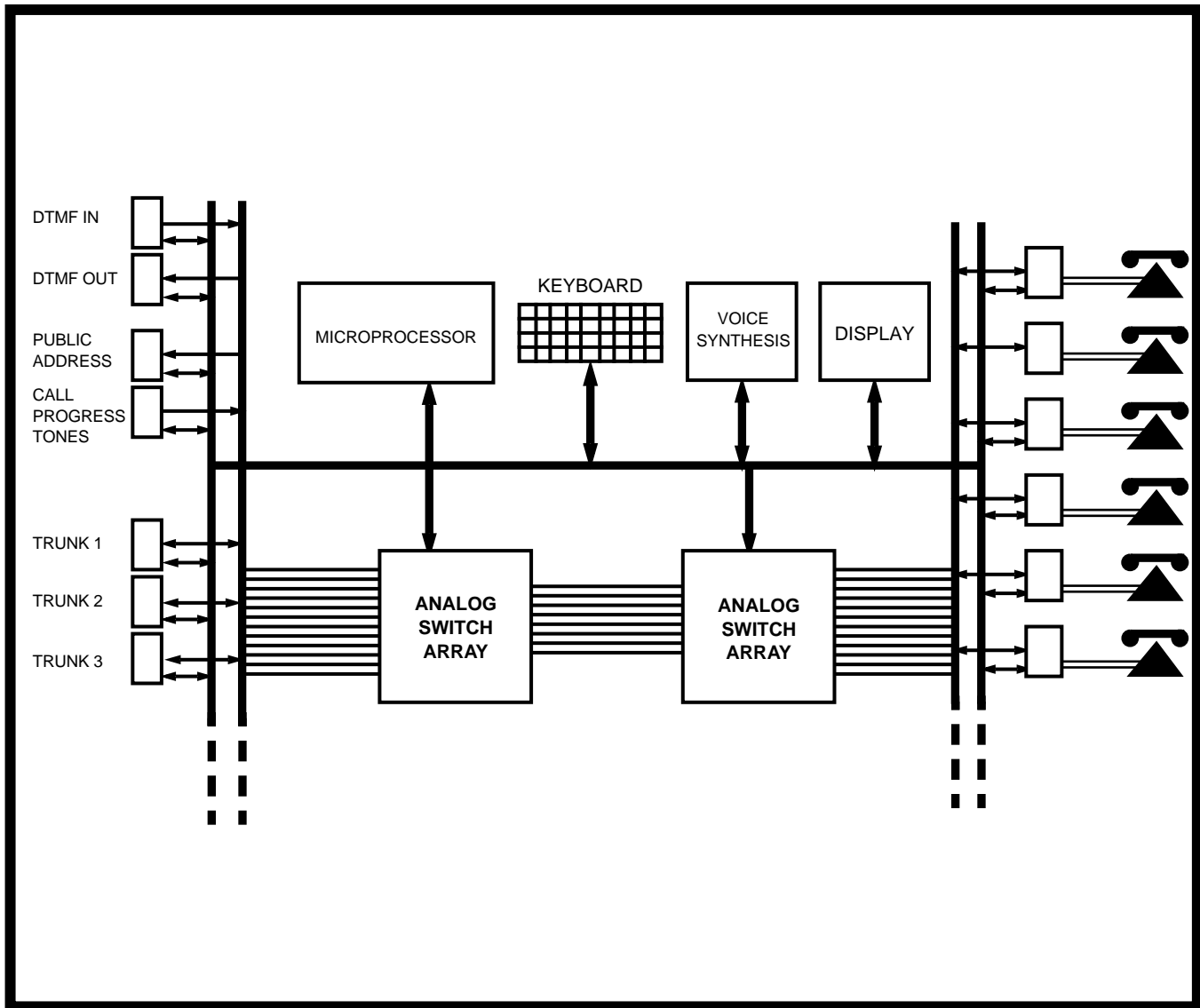

Figure A.8 - Typical Key System Application